

MODEL RG-11 OPTICAL RAIN GAUGE

IRRIGATION APPLICATION NOTES

INSTALLING THE RAIN SENSOR

Mount the rain gauge where it gets a clear measurement of precipitation— away from overhangs, etc.

The mounting arm is designed to fit over a strap 0.75" (19 mm) wide. Two 0.25" (holes 6.35 mm) are placed 0.75" (19 mm) part.

The gland style connector goes in the bottom hole. Be sure to use wire rated for outdoor (high-UV) use.

For conduit applications, the mounting arm may be removed, and the wiring hole drilled out using a step drill to accommodate a 1/2" EMT compression connector or similar style of conduit connector.

Assemble the device as shown. Stretch and release the silicone o-ring (size -036) a few times, so it fits easily in the groove. Optionally, you may coat the O-ring and screws with silicone grease.

For Irrigation Mode, set DIP switch 7 ON and set the other switches to the desired watering amount. See the switch table on page 4 for the other Irrigation settings.

The Rain Gauge must be assembled when dry. Any water trapped inside can condense and cause corrosion. You may optionally add extra desiccant packets (not supplied.) If the Rain Gauge is not subject to splashing or sprayed water, you may optionally vent the enclosure by drilling a 1/8" (3 mm) hole in the bottom of the case.

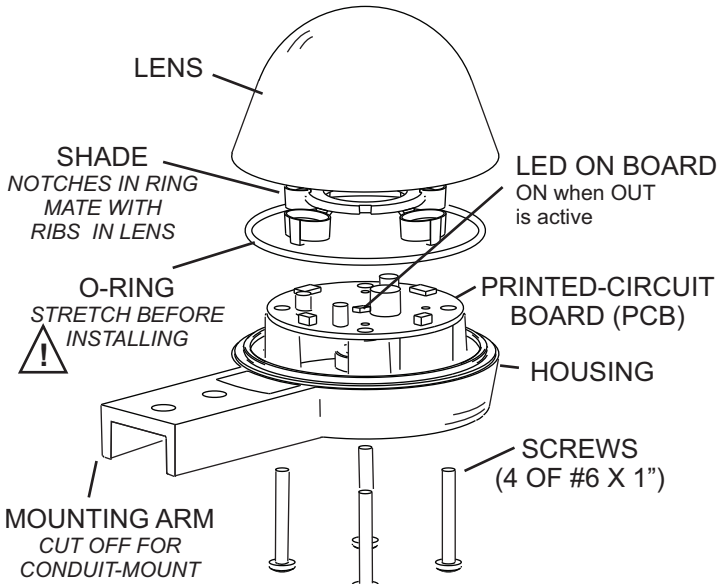

EXPLODED VIEW



VERY IMPORTANT

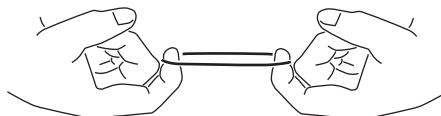

Stretch the O-ring a few times, so that it fits easily into the groove on the lens.

After the unit is assembled, verify that the O-ring is properly seated by confirming that you can see it through the lens, all the way around. The O-ring is slightly under-sized for the groove because that gives the optimal seal.

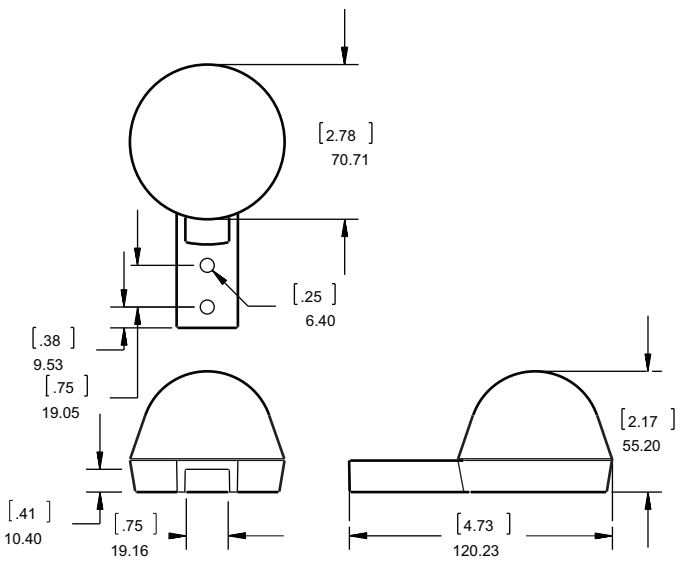

- APPLICATION WARNING -

Do not use the RG-11 in any application where the false indication of water or a missed valid detection of water could cause damage to life or property. It is the responsibility of the system designer / integrator to design redundancy into the system so that the failure of any one component, including the RG-11 or other sensor, does not result in disaster. The manufacturer of the RG-11, Hydreon Corporation, will in no way be liable for consequential damages due to the failure or false indication of one of its sensors.



HYDREON CORPORATION

RAIN GAUGE CONNECTIONS

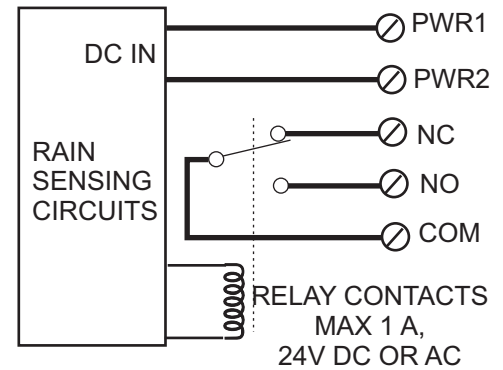
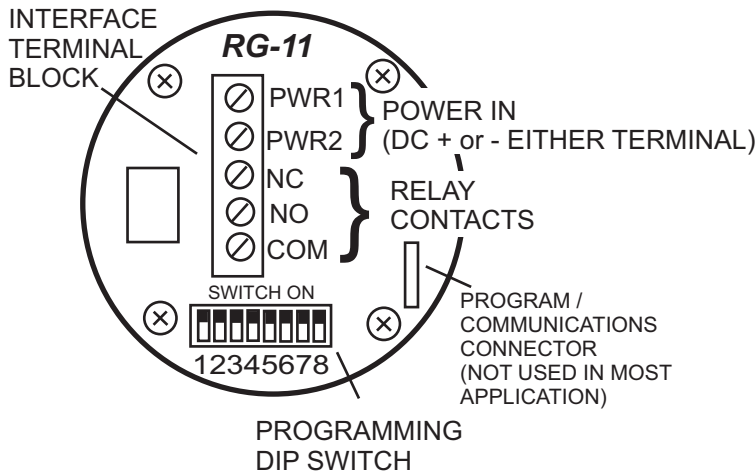

EQUIVALENT SCHEMATIC

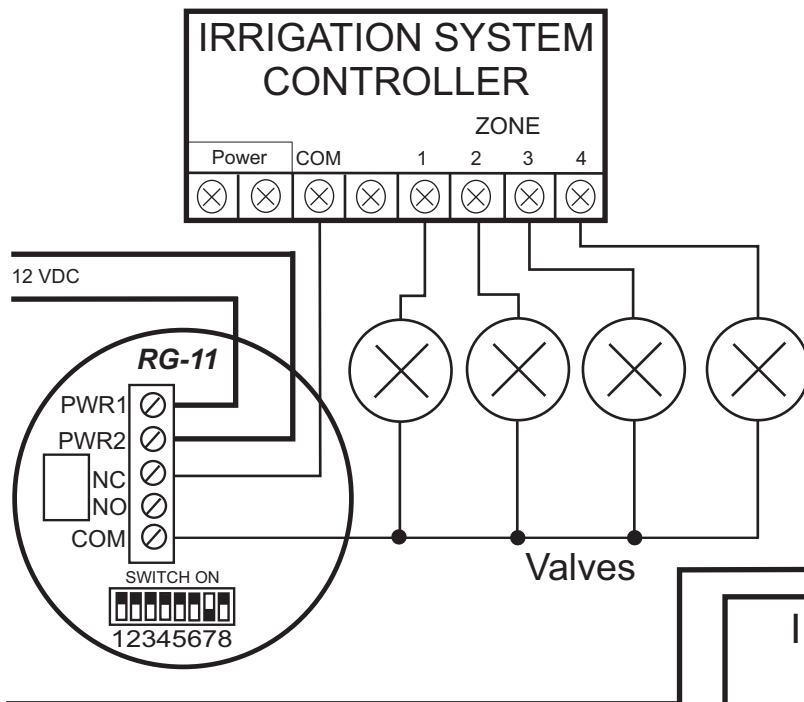

Typical Connection - Rain Sensor Interrupts Valves

In this irrigation setup, the RG-11 interrupts the flow of current to the zone valves when it needs to inhibit watering. When the rain amount hits the threshold, the relay opens the normally closed (NC) connection. When the rain has evaporated, the NC connection closes again, and the irrigation cycle resumes normal operation.

DIP Switch 7 is ON for all Irrigation Mode applications.

Using Sensor Connection

If the irrigation controller is equipped with a Sensor Connection, you may connect the RG-11 directly to the sensor input. The irrigation controller will interpret the data from the RG-11 and properly inhibit watering based on this data.

DIP Switch 7 is ON for all Irrigation Mode applications.

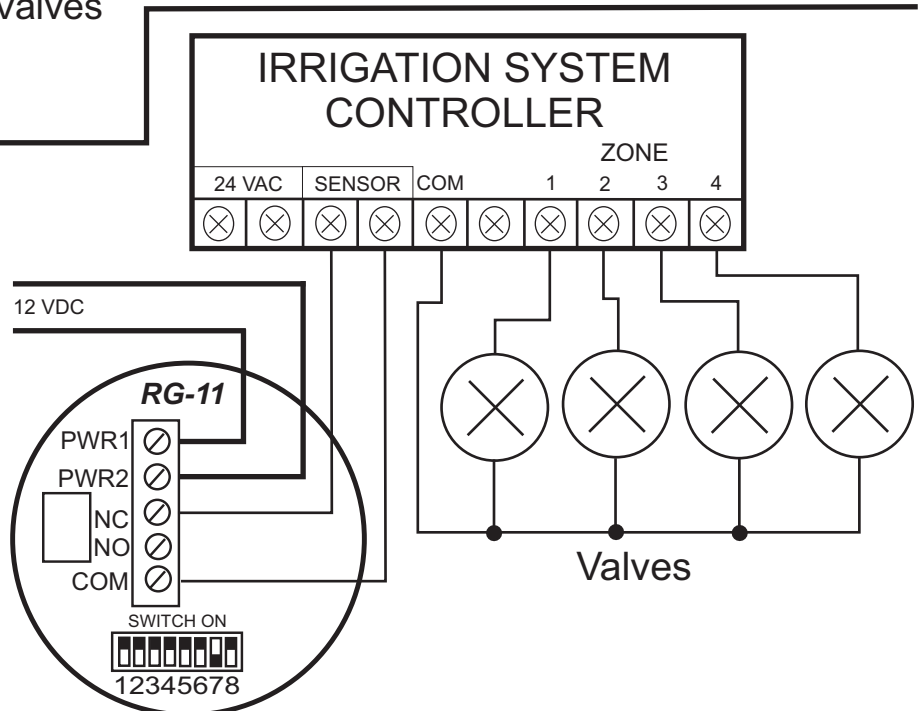

Specifications

Parameter	Value
Input Voltage	Nominal 12 VDC (Range 10 – 15 VDC) 50V surge Reverse polarity protected to 50V
Current Drain	15 mA nominal. (No outputs on, not raining, no heater) about 1.5 mA in micro-power sleep mode. 50 mA - with output on. 55 mA - with heater on
Output	Relay closure, Normally Open and Normally Closed contacts. Max load 1A, 24 VDC.
Operating Temperature range	-40 C to +60C

DIP Switches

Set the DIP switches for the application according to the table on the right; DIP Switch settings correspond to SW 016

OUT LED-- The LED in the center of the circuit board turns on when Normally Open (NO) is on, as an aid to debugging.

Condensation-- Generally, the RG-11 will sense condensation as if it were rainfall, but this seldom amounts to a significant accumulation of water.

Ambient Light Interference-- The RG-11 is almost completely immune to the effects of ambient light, and may freely be mounted in direct sunlight.

Heater Notes-- A built-in low power (0.25W) heater extends operation of the device to freezing (32 F or 0C). Note that this is a very modest amount of power; it will tend to drive off a very modest amount of frost, but will not melt ice.

Mode 4: Irrigation Control								
Rain Gauge output on means inhibit watering.								
Switch							Behavior	
8	7	6	5	4	3	2		1
X	1	0	X	X	0	0	0	Typical Water Control. Inhibit watering for up to 5 days.
					0	0	1	Water More
					0	1	0	Water a lot more
					1	0	0	Water Less
					1	0	1	Water a lot less
				0	X	X	X	Inhibit irrigation during a storm
				1				Allow irrigation during a storm
			0	X	X	X	X	Inhibit irrigation during freeze
			1					Allow irrigation during freeze
0								Normal Evaporation Rate
1								Hi Evaporation Rate

The RG-11 may be set to provide precise control of an irrigation system. Typically, the installation will connect to the COM and NC relay contacts to interrupt the valves when watering should be inhibited.

The nominal irrigation profile is set so that the ground receives an inch of water per week. It will inhibit watering upon the accumulation of 0.2 inches of water, and re-enable the system after that water has evaporated. This can be a short as less than a day, or as long as six days, depending on rainfall. Additional DIP switch settings are provided for allowing more or less watering, as shown in the table below.

Nominally (Switch 4 off), the RG-11 will inhibit watering during a storm, even if not much water has accumulated. The reasoning is that if it is raining hard now, the rainfall is likely to deliver enough accumulation to justify inhibiting at least the current cycle of watering. This prevents the "it's pouring, but my sprinklers are still running" objection from the customer, and the accompanying excessive runoff and muddy ground. The feature may be defeated by turning switch 4 on.

Normally, the RG-11 will inhibit irrigation if the temperature drops below freezing, or nominally about 34 degrees. If SW 5 is on, the RG-11 will allow irrigation below 34 degrees. Micro-power mode is disabled in irrigation control.

Evaporation Rate

Normal Evaporation Rate = 0.11 inches per day

Hi Evaporation Rate = 0.22 inches per day

In irrigation mode, if Switch 8 is on, the control assumes a high evaporation (or transpiration rate). Set this switch to ON for sandy soil or other conditions where the soil tends to dry out quickly. The system will re-enable the irrigation sooner.

IRRIGATION CONTROL STRATEGY

FOR REFERENCE— You do not need to consult for installation.

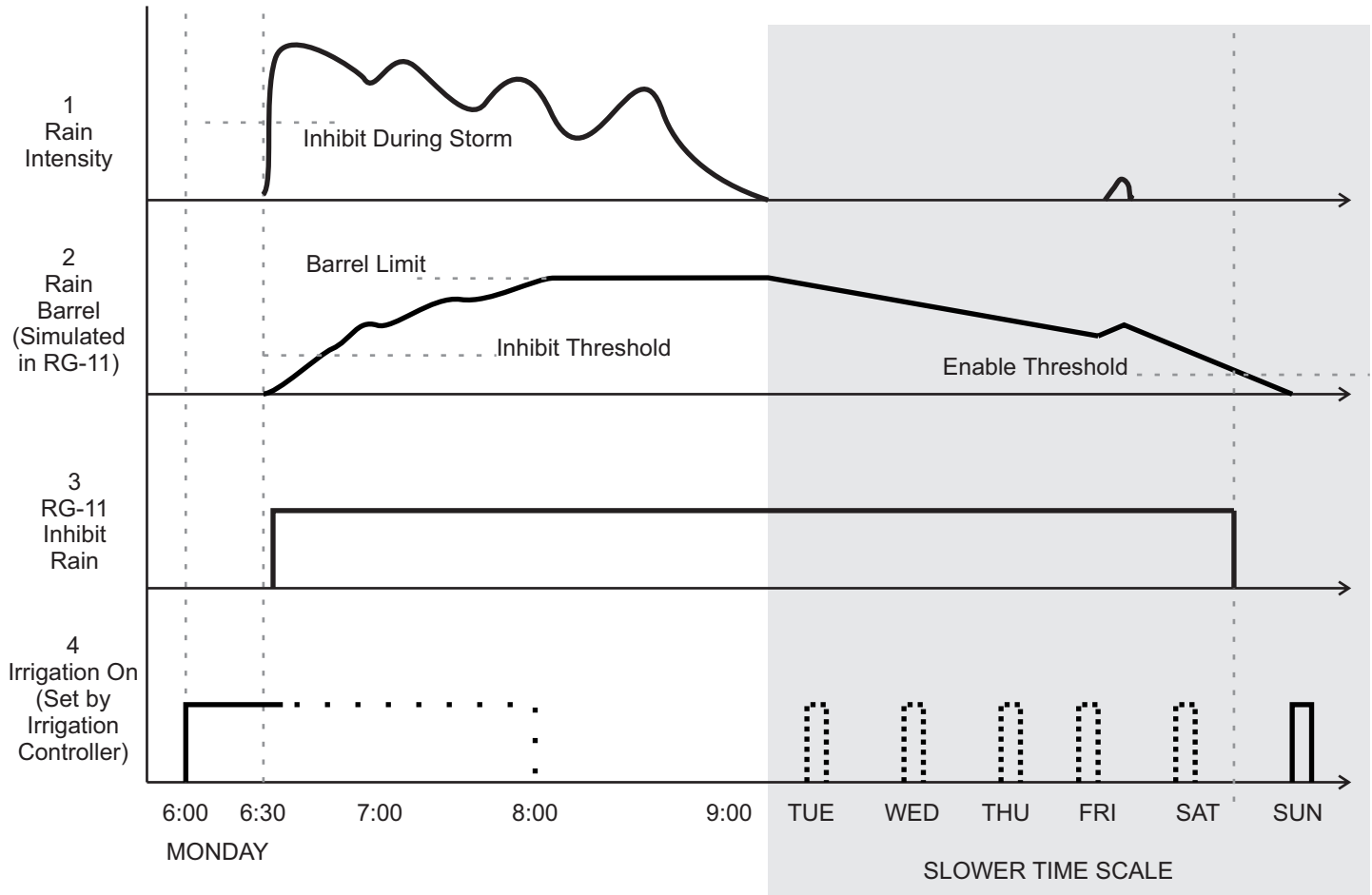

TIME LINE EXPLANATION FOR GRAPH

- At 6:00 AM on Monday, the irrigation controller calls for water, shown in the section 4 on the above graph. The zone valves dutifully open and the sprinkler heads start watering the lawn. The sky is dark with heavy rainclouds, but it has not yet started raining.

- At 6:30, it starts raining and it quickly becomes a downpour. The RG-11 detects the downpour and inhibits irrigation, shown in section 3 on the graph. The RG-11 interrupts the current to the zone valves, and the irrigation water stops. The irrigation controller is still calling for more water, but this is ignored, shown by the dashed lines in section 4.

- The neighbors have a disk-style rain sensor, but this has not yet accumulated enough water to shut off their system, and their sprinklers continue during the downpour.

- By about 6:45, the Rain Barrel accumulation, section 2, in the RG-11 reaches the inhibit threshold. That is, enough water has accumulated that the RG-11 would inhibit the system even if the "inhibit during rainstorm" feature were disabled.

- It continues to rain hard and steady, and the RG-11 continues to record the amount of water accumulated in the simulated Rain Barrel.

- By 8:00, so much water has accumulated that the soil is saturated. The pouring rain that continues now runs off the soil and into the storm sewers. The RG-11 stops recording additional accumulation in Rain Barrel.

- At about 9:15 the storm stops.

- Over the next several days, Tuesday through Friday, the RG-11 slowly decreases the amount of water recorded in the Rain Barrel, shown in section 2 where the line slowly decreases. Each morning, the irrigation control calls for more water, but this is properly inhibited by the RG-11. The lawn received more than enough water for this time period on Monday.

- On Friday afternoon a short summer shower rolls through. This is enough to add a bit more moisture to the soil, which has not yet fully dried out. The RG-11 records this in Rain Barrel, extending the time it inhibits irrigation.

- In mid-afternoon on Saturday, the accumulated water in Rain Barrel has decreased to below the turn on threshold. The lawn has used up most of the water stored in the soil. The RG-11 stops inhibiting irrigation.

- On Sunday morning, the irrigation controller calls for irrigation. By this time the soil is dry enough to need it, and sprinkler heads deliver the proper amount of water.

TROUBLESHOOTING

NOT WATERING ENOUGH

If the RG-11 is inhibiting the watering cycle too much, meaning the soil is too dry before the irrigation system activates, change the DIP switch setting appropriately. Water more-- DIP switch 1 ON-- and Water a lot more-- DIP Switch 2 ON.

WATERING TOO MUCH

If the soil is too wet when the irrigation system activates, you can change the DIP switch settings to Water Less-- DIP switch 3 ON-- and Water a lot less-- DIP switches 3 and 1 ON. These settings will lower inhibit and enable threshold.

DIP SWITCH SETTINGS

For all irrigation modes, DIP switch 7 must be on. Note the position of each numbered switch as compared to the switch setting table. For example, in the DIP switch settings table above, switch 7 is located on the left hand side of the table. Comparing that to the actual DIP switched on the RG-11 board, DIP switch 7 is located on the right side. Be sure the number in the table corresponds to the actual number on the RG-11 board.

NO SIGNAL

Check that the LED is on when the output should switch between NO and NC. If the LED does not light, check the power to the RG-11. Test by pouring water over the sensor. If the LED turns on, check to make sure that the output is wired properly. A common mistake is switching NO and NC or not using the COM and just wiring to the NO and NC.

INHIBIT DURING STORM

By default, the RG-11 is set to inhibit the irrigation system during a storm. This will occur even if not enough water has accumulated. The reasoning is that if it is raining hard now, it is most likely that enough water will accumulate, and we do not want to waste water. The "inhibit during storm" feature may be defeated by turning on DIP switch 4.

SAFETY, LIMITS OF RAIN GAUGE LIABILITY, AND WARRANTY

Only the rain sensor is covered-- absolutely no consequential damages.

It is the responsibility of the systems integrator and purchaser of the Rain Gauge to insure a safe installation. Any mechanical system, including one that incorporates a Rain Gauge, requires appropriate safety interlocks. Hydreon Corporation (Hydreon) warrants only the actual cost of the sensor, and only that it is free from defects in workmanship.

The Rain Gauge is warranted to be free from defects for a period of one year from date of purchase. Under no circumstances will Hydreon be liable for any consequential damages due to failure or any other mishap involving a Rain Gauge. Hydreon's liability in the event of a failure, or inability to sense a condition, is limited to the actual cost of the particular sensor. Explicitly, if other objects are destroyed due to water damage, or if any object is destroyed because of a false indication of water, Hydreon is in no way whatsoever liable for anything other than the cost of the Rain Gauge, and then only if the Rain Gauge is shown to have some defect in materials or workmanship. Limitations and imperfections of the Rain Gauge do not constitute a defect. Further, if some valuable data is not gathered because an erroneous indication of any sort due to the Rain Gauge, Hydreon is liable only for the cost of the Rain Gauge.

It is the responsibility of the system designer and purchasers of the Rain Gauge to ensure that a failure of the Rain Gauge will not cause consequential damages. If a failure in Rain Gauge would cause disaster, we recommend against deployment of the Rain Gauge, or against the system in which the Rain Gauge is deployed. If a failure of a Rain Gauge would cause great expense, Hydreon recommends redundant Rain Gauges, and even in that case do not assume any liability for consequential damages. It is the responsibility of the system designer and purchasers of the Rain Gauge to be aware of performance limitations of the device. If a Rain Gauge fails for any reason Hydreon will not be responsible for the labor of servicing and/or installing and/or removing the Rain Gage. Labor is NOT COVERED. Hydreon recommends that the system designer perform a Failure-Mode Effects Analysis that includes the possibility of Rain Gauge failure. If a potential purchaser of the Rain Gauge does not agree with these terms, we ask that the potential purchaser not buy the Rain Gauge. Deployment of the Rain Gauge implies understanding and agreeing to these limits of liability.

Apply engineering judgment: Hydreon does not claim the RG-11 is a perfect rain sensor. It is what it is, and senses what it senses.

CASE and COSMETIC POLICY

Some amount of yellowing or discoloration of the case is considered normal cosmetic aging of the device, and sensors so affected will not be replaced under warranty. Tiny cracks or crazing within the lens is also considered cosmetic, and units so affected will be replaced only if they are deemed by Hydreon Corporation to be considered to be of a functional nature.